

TOLKAR[®]

SMARTEX[®]

Technological, Ecological, Economical Differences

Technological,
Ecological,
Economic Differences



Rising Stars...



WORLD'S MOST ADVANCED WASHING TECHNOLOGY

%100 MEASURABLE SUSTAINABLE ECONOMICAL & GREEN

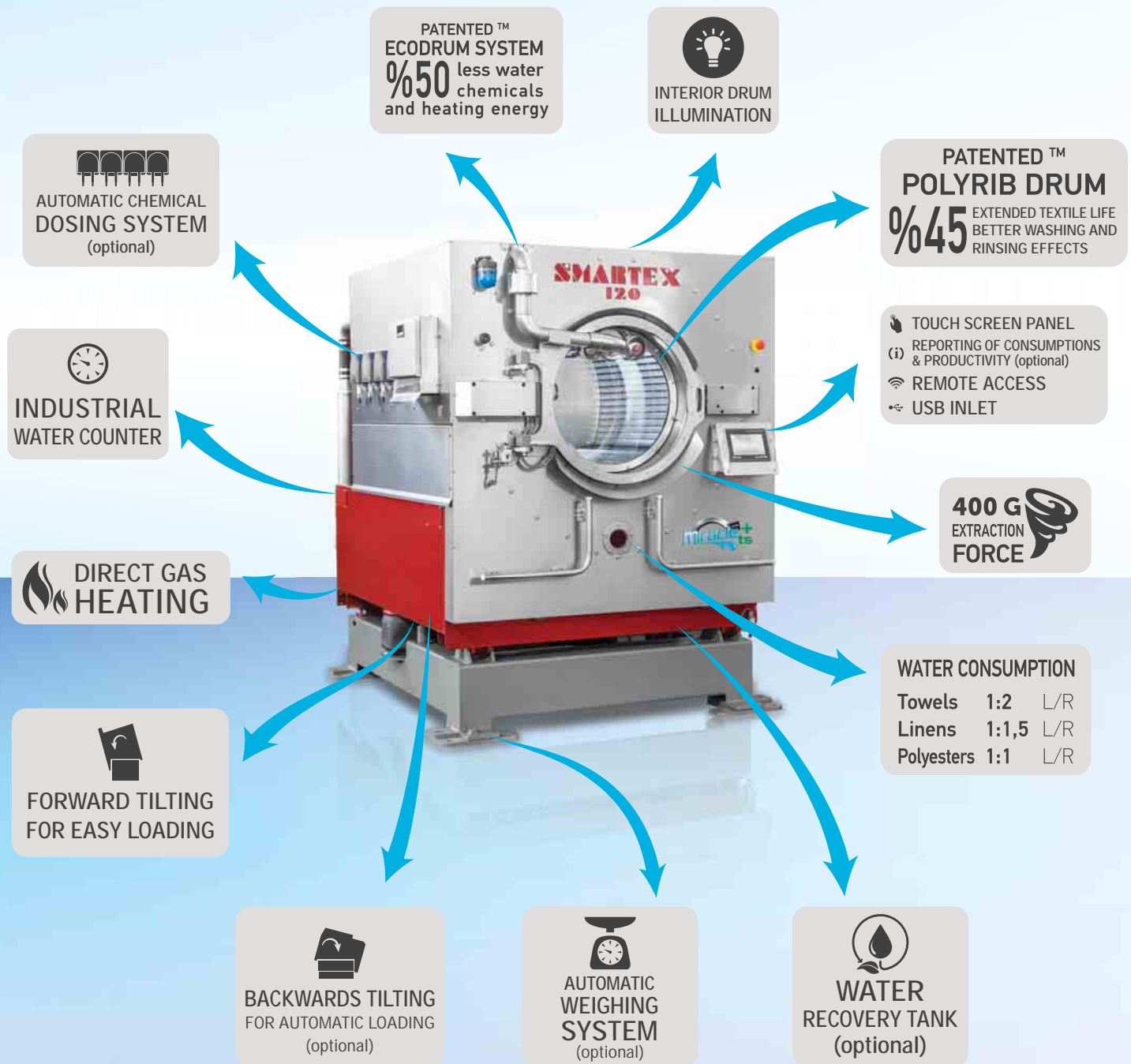



INDEX

Company Profile.....	4
Full Automatic Washer Extractors.....	6
Tumble Dryers.....	20
Flatwork Ironers.....	24
Chest Heated Ironers.....	28
Linen And Towel Folding Machines.....	32
Feeders.....	34
Auxiliary Equipments.....	35
Distributorships.....	36
Social Responsibility Projects.....	38
After Sales Services.....	40

COMPANY PROFILE

TOLKAR has established in 1969 as a family business regarding to produce textile processing and commercial laundry machines at IZMIR, Camdibi. From the very first date, continuous development, better quality and customer satisfaction have made up a principle by TOLKAR where at the present day constitute from 2 splendid innovative production factories in IZMIR Ataturk Industrial Zone along with distributorship of the leader manufacturers of their sectors for supplementary products and more than 300 employees of its Group Companies. TOLKAR has its own reputation in the world by reaching the production capacity of 3500 machines per year of various models and exports more than 70 countries abroad. Besides, 16 Regional Branches with their Service Managements in Turkey and more than 25 distributors with their Service Managements in abroad ensure the fastest sales and after sales servicing facilities to their customers.

Along the stage of development, TOLKAR is devoted itself to differ as technological, ecological and economical supremacies. Utilization of latest technologies and techniques in production, TOLKAR performs from starting up the design phase, consequent research & development, prototype production, factory tests, field tests and mass production by accomplishing the mentioned triple mission. All revolutionary inventions those differs as technological, ecological and economical supremacies;

have been protected with their Patents in all over the world. All our innovations offer to our customers uncompromised and inapproachable savings where at the same time minimize the effluent in order to protect the environment for a clean world to the next generations.

TOLKAR provides all capacities of commercial laundry & textile processing machines and equipments right along side the distributorship of the leader brands in their sector such as LAVATEC, BIKO, COLMAC, SPEEDQUEEN, CHICAGO and RENZACCI. In 2008, after acquisition of SMARTEX and its patented "Smart Balancing System", TOLKAR becomes the unique company who has the capability of manufacturing very high speed washer extractors by exerting 400 G force while spinning. Yet as the first and only producer of the patented innovation introduced PolyRib ECO Drum, TOLKAR is proud to offer SMARTEX MIRACLE series which saves dramatically 50 % from the water, chemicals and heating energy. In 2013, TOLKAR is proud to announce SMARTEX Miracle + TS which has in built water recovery tank system that saves additional 25 % water saving additional to SMARTEX Miracle series.

With the consciousness of change alone is unchanging, TOLKAR will perpetuate the leadership in accordance with its mission to next generations. Feel like a star with TOLKAR.





Final Testing Area



Machining Section



SMARTEX MIRACLE

Fully automatic washer extractors

WORLD S MOST ECONOMIC WASHING SYSTEMS



**FIRST AND THE ONLY
GAS HEATED
IN THE WORLD**

WATER CONSUMPTION

Towels	1:2	L/R
Linens	1:1,5	L/R
Polyesters	1:1	L/R

**PATENTED™
ECODRUM SYSTEM**
%50 less water
chemicals
and heating energy

**PATENTED™
POLYRIB DRUM**
%45 longer
textiles life

**PATENTED™
SMART BALANCING**
%20 less
drying
time
& drying energy

SMARTEX MIRACLE

Fully automatic washer extractors



VNC Virtual Network Computing



TOLKAR ULTIMATE CONTROL SYSTEM

- remote access recipe preparation, upload & download, recipe transfer to desired machines and software updates via remote access
- USB programme transfer
- 100 recipes each, 100 step
- (i) reporting performance and maintenance reporting ability consumptions of water, steam, electricity, chemicals etc along with productivity



PLC controlled touch screen

400 G
EXTRACTION FORCE

totally vibration free



precious weight scale system

Automatic (only required) water, steam, chemical intake according to scaled textiles (optional)



AUTOMATIC LIQUID DETERGENT DOSING SYSTEM

in built dosing pumps for liquid detergent dosing. Integrated with reporting and weight scale systems (optional)

SMARTEX MIRACLE

Fully automatic washer extractors

60 - 120 kg

TUSiD 2012
INDUSTRIAL PRODUCTS COMPETITION
SMARTEX MIRACLE
Gas Heated Laundry Systems



		Miracle 60	Miracle 120
Capacity	(kg/batch)	60	120
Drum Volume	(lt)	545	1.125
Motor Power	(Kw)	7,5	18,5
Gas Heat Power	(Kcal/h)	33.000	66.000
Width	(mm)	1.260	1.530
Depth	(mm)	1.890	2.415
Height	(mm)	1.765	2.030
Tilted Height	(mm)	--	2.370
Weight	(kg)	1.290	2.230

Technical Specifications

Read the QR code to watch PolyRib ECO Drum Technology





TUSiD 2009
INDUSTRIAL PRODUCTS COMPETITION
SMARTEX MIRACLE
PolyRib ECO Drum Technology

SMARTEX MIRACLE

Fully automatic washer extractors

135 - 150 kg



		Miracle 135	Miracle 150
Capacity	(kg/batch)	135	150
Drum Volume	(lt)	1.320	1.480
Motor Power	(Kw)	18,5	22
Gas Heat Power	(Kcal/h)	66.000	66.000
Width	(mm)	1.585	1.750
Depth	(mm)	2.448	2.480
Height	(mm)	2.056	2.120
Tilted Height	(mm)	2.456	2.461
Weight	(kg)	2.700	2.980

Technical Specifications



SMARTEX MIRACLE

Fully automatic washer extractors

225 - 340 kg



		Miracle 225	Miracle 340
Capacity	(kg/batch)	225	340
Drum Volume	(lt)	2.280	3.398
Motor Power	(Kw)	15	18,5
Gas Heat Power	(Kcal/h)	132.000	--
Width	(mm)	1.915	2.175
Depth	(mm)	2.275	2.550
Height	(mm)	2.530	2.730
Tilted Height	(mm)	2.845	3.110
Weight	(kg)	4.530	6.670



BACKWARDS TILTING
EASY LOADING & UNLOADING
(optional)

Technical Specifications



SMARTEX MIRACLE + TS

Fully automatic washer extractors

120 - 135 - 150 - 225 kg

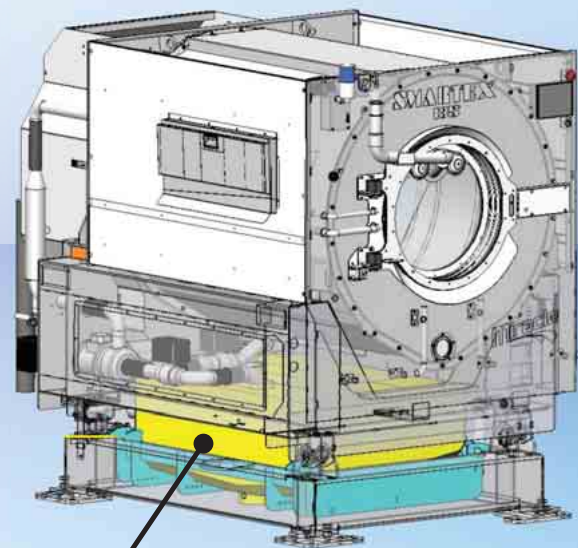

Water recovery tank

Tank System
WATER RECOVERY
Technology
**%60 WATER
SAVING**

Read the QR code to watch Tank System Technology

Technical Specifications



		Miracle 120	Miracle 135	Miracle 150	Miracle 225
Capacity	(kg/batch)	120	135	150	225
Drum Volume	(lt)	1.125	1.320	1.480	2.280
Recovery Tank	(lt)	360	400	450	700
Motor Power	(Kw)	18,5	18,5	22	15
Gas Heat Power	(Kcal/h)	66.000	66.000	66.000	132.000
Width	(mm)	1.530	1.585	1.750	1.915
Depth	(mm)	2.415	2.448	2.480	2.275
Height	(mm)	2.030	2.056	2.120	2.530
Tilted Height	(mm)	2.370	2.456	2.461	2.845
Weight	(kg)	2.230	2.700	2.980	4.530

HYDRA Mini Midi Maxi

Fully automatic washer extractors



TUSiD 2007
INDUSTRIAL PRODUCTS COMPETITION

HYDRA POWERSPRAY
Power Spray Technology



Powerspray
(optional)

%35 less rinsing water
%25 less rinsing time



%100 HEAVY INDUSTRIAL CONSTRUCTION

- ST37 balance weight system
- Engineered front & rear plates and drum construction
- Enhanced new belt-pulley system and bearing housing
- Unwelded inner drum



HYDRA Mini Midi Maxi

Fully automatic washer extractors



TOLKAR ULTIMATE CONTROL SYSTEM

- remote access recipe preparation, upload & download, recipe transfer to desired machines and software updates via remote access
- USB programme transfer
- 5" TFT COLORFUL SCREEN
- MANUEL CONTROL OPTION
- 100 recipes each, 250 step
- (i) reporting** performance and maintenance reporting ability consumptions of water, steam, electricity, chemicals etc along with productivity **(Optional)**

FULLY STAINLESS STEEL

inner & outer drums, front, sides and top covers



LIQUID CHEMICAL DOSING SYSTEM

in built dosing pumps for liquid chemical dosing
Integrated with reporting and weight scale systems
(optional)

HYDRA Mini

Fully automatic washer extractors

10-12-20-25-30 kg

HYDRA Midi

Fully automatic washer extractors

35-40-50 kg



		Hydra Mini 10	Hydra Mini 12	Hydra Mini 20	Hydra Mini 25	Hydra Mini 30	Hydra Midi 35	Hydra Midi 40	Hydra Midi 50
Capacity	(kg/batch)	10	12	20	25	30	35	40	50
Drum Volume	(lt)	100	120	208	254	300	350	400	500
Motor Power	(Kw)	1,5	2,2	3	4	4	5,5	5,5	7,5
Heating Power	(Kw)	6	8	9	12	15	15	18	24
Width	(mm)	825	825	990	990	990	1.180	1.180	1.180
Depth	(mm)	860	970	1.030	1.155	1.300	1.275	1.345	1.525
Height	(mm)	1.190	1.190	1.450	1.450	1.450	1.780	1.780	1.780
Weight	(kg)	350	390	595	700	770	1.075	1.125	1.230

Technical Specifications





HYDRA Maxi

Fully automatic washer extractors

60-80-100 kg



		Hydra Maxi 60	Hydra Maxi 80	Hydra Maxi 100
Capacity	(kg/batch)	60	80	100
Drum Volume	(lt)	600	800	1.000
Motor Power	(Kw)	11	15	18,5
Heating Power	(Kw)	36	39	42
Width	(mm)	1.460	1.710	1.710
Depth	(mm)	1.590	1.730	1.905
Height	(mm)	2.000	2.040	2.040
Weight	(kg)	2.250	2.990	3.500

Technical
Specifications



TOLKAR MIRACLE

Fully automatic washer extractors

50 - 60 kg



Technical Specifications



		Miracle 50	Miracle 60
Capacity	(kg/batch)	50	60
Drum Volume	(lt)	500	600
Motor Power	(Kw)	7,5	11
Gas Heat Power	(Kcal/h)	33.000	33.000
Width	(mm)	1.180	1.460
Depth	(mm)	1.525	1.590
Height	(mm)	1.780	2.130
Weight	(kg)	1.230	2.300

* All specifications and features of Hydra Series will come along with Tolkar Miracle as standard.

WATER CONSUMPTION

Towels	1:2	L/R
Linens	1:1,5	L/R
Polyesters	1:1	L/R

**PATENTED™
ECODRUM SYSTEM**
%50 less water
chemicals
and heating energy

**PATENTED™
POLYRIB DRUM**
%45 longer
textiles life

**FIRST AND THE ONLY
GAS HEATED
IN THE WORLD**



HYDRA DOUBLEDECK

Fully automatic washer extractors

10 / 10 kg



Doubledeck Washer

Capacity	(kg/batch)	10
Drum Volume	(lt)	100
Motor Power	(Kw)	1,5
Heating Power	(Kw)	6
Width	(mm)	825
Depth	(mm)	885
Height	(mm)	1.225
Weight	(kg)	350

Doubledeck Dryer

Capacity (1/20)	(kg/batch)	10
Drum Volume	(lt)	200
Motor Power	(Kw)	0,37
Heating Power	(Kw)	14
Width	(mm)	825
Depth	(mm)	915
Height	(mm)	955
Weight	(kg)	140

Technical Specifications



MIRACLE HYGIENE

Hygienic barrier type washer extractors

135 - 225 kg



Technical Specifications



		Miracle Hygiene 135	Miracle Hygiene 225
Capacity	(kg/batch)	135	225
Drum Volume	(lt)	1.320	2.280
Motor Power	(Kw)	18,5	15
Gas Heat Power	(Kcal/h)	66.000	132.000
Width	(mm)	1.882	2.397
Depth	(mm)	2.475	2.742
Height	(mm)	2.206	2.675
Tilted Height	(mm)	2.456	2.845
Weight	(kg)	2.700	4.680



**FIRST AND THE ONLY
FORWARD TILTING
IN THE WORLD**

* All specifications and features of Miracle Series will come along with SMARTEX MIRACLE HYGIENE as standard.

NORMA HYGIENE

Hygienic barrier type washer extractors

20 - 40 - 60 - 90 kg



Technical Specifications



		Norma Hygiene 20	Norma Hygiene 40	Norma Hygiene 60	Norma Hygiene 90
Capacity	(kg/batch)	20	40	60	90
Drum Volume	(lt)	200	400	600	900
Motor Power	(Kw)	3	5,5	11	15
Heating Power	(Kw)	9	18	45	45
Width	(mm)	1165	1355	1405	1685
Depth	(mm)	1035	1225	1450	1450
Height	(mm)	1565	1775	1995	2060
Weight	(kg)	785	1190	1600	2200

* All specifications and features of Hydra Series will come along with TOLKAR NORMA HYGIENE as standard.

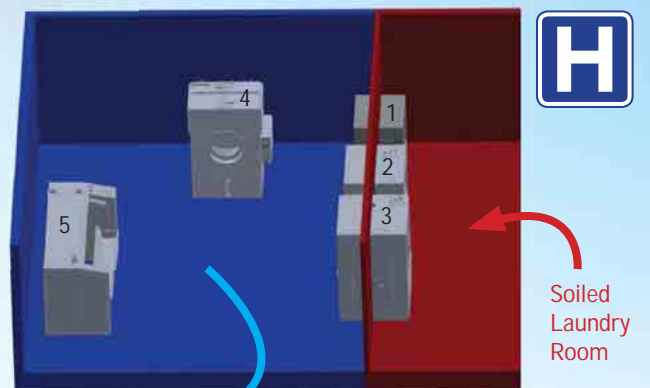

Clean Laundry Room

- 1- Norma Hygienic Barrier Type Washer Extractors - 20 kg
- 2- Norma Hygienic Barrier Type Washer Extractors - 40 kg
- 3- Norma Hygienic Barrier Type Washer Extractors - 60 kg
- 4- Carina Tumble Dryer
- 5- Vela Flatwork Ironer



Soiled Laundry Room

CARINA

Tumble dryers machines

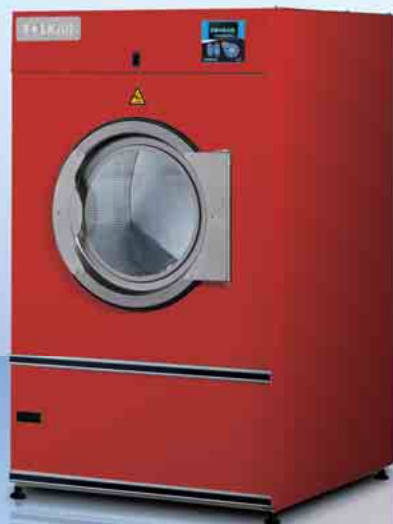

COPPER ALUMINUM SERPENTINES

Fast heating and cooling with easy maintenance (for steam heated models)



HUMIDITY CONTROLLED DRYING



COOL DOWN

No more wrinkles, hardness and thermal shock on textiles





GAS HEATING

OPTION IN ALL MODELS



TOLKAR ULTIMATE CONTROL SYSTEM

-  remote access recipe preparation, upload & download, recipe transfer to desired machines and software updates via remote access
-  USB programme transfer
- 4,3" TFT COLORFUL SCREEN
- MANUEL CONTROL OPTION
- 15 programmes
- (i) **reporting** performance and maintenance reporting ability consumptions of steam, electricity along with productivity



BIDIRECTIONAL ROTATION



FORWARD TILTING FOR EASY UNLOADING
(STANDARD FOR MODELS 2700-4069-5070)



BACKWARDS TILTING
EASY LOADING
(for 2700-4069-5070)
(Optional)

CARINA

Tumble dryers

305-400-450-600-605-800

CARINA

Tumble dryers

905-1200-1500



Technical Specifications



		Carina 305	Carina 400	Carina 450	Carina 600	Carina 605	Carina 800*	Carina 905	Carina 1200	Carina 1500
Type		Elc. / Stm. / Gas	Electric	Elc. / Stm. / Gas	Electric	Elc. / Stm. / Gas	Electric	Elc. / Stm. / Gas	Elc. / Stm. / Gas	Elc. / Stm. / Gas
Capacity 1/20 - 1/15		15/20	20/27	22/30	30/40	30/40	40/53	45/60	60/80	75/100
Drum Volume	(lt)	305	400	450	600	605	800	905	1198	1492
Drum Motor Power	(Kw)	0,75	0,75	0,75	0,75	0,75	1,5	1,5	3	3
Fan Motor Power	(Kw)	0,75	0,75	0,75	0,75	0,75 / 1,5 / 0,75	1,5	1,5 / 2,2 / 2,2	2,2	2,2 / 3 / 3
Electric Heating Power	(Kw)	14	14	18	21	21	42	42	42	42
Steam Consumption	(kg/h)	38	-	38	-	44	-	81	95	110
Gas Heat Power	(Kcal/h)	18.000	-	23.000	-	25.000	-	33.000	37.125	44.550
Air Flow	(m³/h)	1.300	1.300	1.300	1.300	1.500	3.900	3.900 / 4.500 / 4.500	4.500 / 6.400 / 6.400	4.500 / 6.400 / 6.400
Width	(mm)	970	970	970	1.040	1.040	1.040	1.610	1.610 / 1.640 / 1.610	1.610 / 1.640 / 1.610
Depth	(mm)	870	870	1100	1.215	1.215	1.650	1.440	1.700	1.960
Height	(mm)	1.750 / 1.750 / 1.910	1.750	1.750 / 1.750 / 1.910	1.775	1.775 / 1.860 / 1.910	1.860	2.060 / 2.250 / 2.346	2.060 / 2.250 / 2.346	2.060 / 2.250 / 2.346
Weight	(kg)	280	285	295	385	365	450	650	725	900



		Carina 2700	Carina 4069	Carina 5070
Type		Steam / Gas	Steam / Gas	Steam / Gas
Capacity 1/20 - 1/15		135 / 180	200 / 270	250 / 340
Drum Volume	(lt)	2.700	4.069	5.070
Drum Motor Power	(Kw)	3	5,5	5,5
Fan Motor Power	(Kw)	2x3	4x3 / 2x3	4x3 / 2x3
Steam Consumption	(kg/h)	270	400	500
Gas Heat Power	(Kcal/h)	99.000	148.500	173.250
Air Flow	(m ³ /h)	11.000	22.000 / 11.000	22.000 / 11.000
Width	(mm)	1.950	2.240 / 2.205	2.500 / 2.470
Depth	(mm)	2.335	2.642	2.685
Height	(mm)	2.850 / 3.029	3.105 / 3.256	3.160 / 3.390
Tilted Height	(mm)	2.989 / 3.280	3.390 / 3.583	3.390 / 3.689
Weight	(kg)	2.300	3.280	3.910

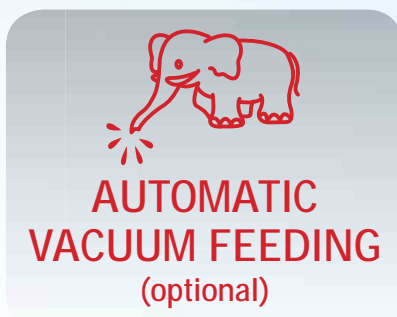

Technical
Specifications



VELA

Flatwork ironers



GAS HEATING
OPTION IN ALL MODELS

ACCORDING TO TEXTILE TYPES
VELOCITY
CONTROLLED ROLLS

TOLKAR ULTIMATE CONTROL SYSTEM

-  **remote access** upload & download to desired machines and software updates via remote access
-  **USB** software and data transfer
-  **4.3" TFT COLORFUL SCREEN**
-  **reporting** performance and maintenance reporting ability consumptions of steam, electricity etc along with productivity (Optional)

VELA
Flatwork ironers



**PADDLE BOX AND
FAN SYSTEM FOR
HUMIDITY AND STEAM
COLLECTION**

**GENUINE
NOMEX
BELTS**

**STAINLESS
STEEL
MAIN ROLL**
(optional)

IN BUILT FOLDING
Vela 5530 & 7530 models offer
2-8 primary folds between
30-50 cm length (optional)

VELA Flatwork ironers

320-500-550 mm
Cylinder Diameter



VELA Flatwork ironers

650 - 750 mm
Cylinder Diameter



Technical
Specifications



		Vela 3218	Vela 5015	Vela 5515	Vela 5518	Vela 5520	Vela 5525	Vela 5530
Type		Elk. / Gas	Elk. / Stm.	Gas	Elk. / Stm. / Gas	Elk. / Stm. / Gas	Elk. / Stm. / Gas	Elk. / Stm. / Gas
Cylinder Diameter	(mm)	320	500	550	550	550	550	550
Cylinder Width	(mm)	1.800	1.500	1.500	1.800	2.000	2.500	3.000
Ironing Capacity	(kg/h)	24	40 / 40	50	42 / 42 / 52	45 / 45 / 55	50 / 50 / 60	55 / 55 / 65
Working Speed	(m/min)	2-6	3,5 - 10,5	3,5 - 10,5	3,5 - 10,5	3,5 - 10,5	3,5 - 10,5	3,5 - 10,5
Motor Power	(Kw)	0,37	1,1	1,1	1,1	1,1	1,1	1,1
Fan Motor Power	(Kw)	0,37	0,37	0,37	0,37	0,37	0,37	0,37
Electric Heating	(Kw)	24	27	--	22,5	22,5	27	31,5
Steam Inlet	(kg/h)	--	35	--	40	45	50	55
Gas Heating Power	(Kcal/h)	20.625	--	22.280	23.700	26.350	28.900	31.570
Width	(mm)	2.530 / 2.690	2.230 / 2.230	2.390	2.530 / 2.530 / 2.690	2.730 / 2.730 / 2.890	3.230 / 3.390 / 3.390	3.730 / 3.890 / 3.890
Depth	(mm)	950 / 950	1.150 / 1.200	1.200	1.150 / 1.200 / 1.200	1.150 / 1.200 / 1.200	1.150 / 1.200 / 1.200	1.150 / 1.200 / 1.200
Height	(mm)	990 / 1.310	1.355 / 1.355	1.675	1.355 / 1.355 / 1.675	1.355 / 1.355 / 1.675	1.355 / 1.355 / 1.675	1.355 / 1.355 / 1.675
Weight	(kg)	500	810	810	885	930	1.050	1.170

Tolkar reserves changing the technical specifications of the machines due to technological necessities without prior notice
Capacities are given for the laundry extracted at 300 G force.

It is recommended that textiles keeping more water and moisture due to thickness or knit raw material should be pre dried in the dryers before ironing.



VELA Flatwork ironers

950-1200 mm
Cylinder Width



		Vela 6530	Vela 7520	Vela 7525	Vela 7530	Vela 9530	Vela 12030
Type		Elk. / Stm. / Gas	Elk. / Stm. / Gas	Elk. / Stm. / Gas	Elk. / Stm. / Gas	Stm. / Gas	Stm. / Gas
Cylinder Diameter	(mm)	650	750	750	750	950	1.200
Cylinder Width	(mm)	3.000	2.000	2.500	3.000	3.000	3.000
Ironing Capacity	(kg/h)	65 / 65 / 80	65 / 65 / 80	74 / 74 / 90	80 / 80 / 100	110 / 150	140 / 200
Working Speed	(m/min)	4-12	4,5 / 13,5	4,5 / 13,5	4,5 / 13,5	6-18	7-22
Motor Power	(Kw)	1,1	1,1	1,1	1,1+0,37	3 / 2x1,5	3 / 2x1,5
Fan Motor Power	(Kw)	0,37	0,37	0,37	2x0,37	3x0,37	3x0,37 / 4x0,37
Electric Heating	(Kw)	32	30	36	40	72	84
Steam Inlet	(kg/h)	65	65	70	75	100	150
Gas Heating Power	(Kcal/h)	28.000	26.350	31.570	35.100	66.000	82.500
Width	(mm)	3.835 / 3.925 / 3.925	2.835 / 2.995 / 2.995	3.335 / 3.425 / 3.425	3.835 / 3.925 / 3.925	4.110	4.110 / 4.150
Depth (Elc.)	(mm)	1.400 / 1.450 / 1.450	1.400 / 1.450 / 1.540	1.400 / 1.450 / 1.540	1.400 / 1.450 / 1.540	1.935	2.780
Height	(mm)	1.800 / 1.800 / 2.120	1.850 / 1.800 / 2.170	1.850 / 1.850 / 2.170	1.850 / 1.850 / 2.170	2.080	2.430
Weight	(kg)	1.570	1.475	1.600	1.725	2.525 / 2.325	3.990 / 3.640

Tolkar reserves changing the technical specifications of the machines due to technological necessities without prior notice.
Capacities are given for the laundry extracted at 300 G force.
It is recommended that textiles keeping more water and moisture due to thickness or knit raw material should be pre-dried in the dryers before ironing.

VELA CHI
Chest heated ironers



GAS HEATING
OPTION IN ALL MODELS

**HUMIDITY DISCHARGE
VIA INVERTER
CONTROLLED FANS
FROM INSIDE
THE ROLLS**

ROLLS

VELA CHI
Chest heated ironers



TOLKAR ULTIMATE CONTROL SYSTEM

-  **remote access** upload & download to desired machines and software updates via remote access
-  **USB** software and data transfer
-  **4.3" TFT COLORFUL SCREEN**
-  **reporting** performance and maintenance reporting ability consumptions of steam, electricity etc along with productivity (Optional)

**HIGH PRESSURE RESIST (12 bars)
GERMAN MADE CHESTS**

MAXIMUM PRESSURE & PRESSING quality via special spring crushes and pneumatic systems

VELA CHI

Chest heated ironers

800-1200 mm
Cylinder Diameter



Technical
Specifications



VELA CHI

Chest heated ironers

3000-3300-3500 mm
Cylinder Width



Gas heating system



Chest and drive system

		Vela chi 18030	Vela chi 28030	Vela chi 38030	Vela chi 18033	Vela chi 28033	Vela chi 38033	Vela chi 112030	Vela chi 212030	Vela chi 312030	Vela chi 112035	Vela chi 212035	Vela chi 312035
Type		Elc./Stm./Gas	Elc./Stm./Gas	Steam/Gas	Steam/Gas	Steam/Gas	Steam/Gas	Elc./Stm./Gas	Steam/Gas	Steam/Gas	Steam/Gas	Steam/Gas	Steam/Gas
Number of Cylinder	(pcs)	1	2	3	1	2	3	1	2	3	1	2	3
Cylinder Diameter	(mm)	800	800	800	800	800	800	1200	1200	1200	1200	1200	1200
Cylinder Width	(mm)	3000	3000	3000	3300	3300	3300	3000	3000	3000	3500	3500	3500
Ironing Capacity	(kg/h)	120	300	550	135	330	600	250	550	900	300	650	1050
Ironing Capacity	(pcs/h)	200	500	850	220	550	950	400	850	1500	400	850	1500
Working Speed	(m/min)	3-12	6-21	9-36	3-12	6-21	9-36	4-18	9-38	15-54	4-18	9-39	12-54
Motor Power	(Kw)	4	7,5	15	4	7,5	15	7,5	22	37	11	22	37
Fan Motor Power	(Kw)	0,75	1,1	1,5	7,5	1,1	1,5	1,5	2,2	2,2	2,2	2,2	3
Gas Heat Power	(Kcal/h)	66.825	123.750	195.525	66.825	123.750	195.525	106.425	200.475	297.000	125.400	247.500	374.550
Steam Inlet	(Kcal/h)	120	220	350	130	240	380	190	360	530	225	440	670
Width	(mm)	4.120	4.120	4.120	4.150	4.150	4.150	4.890	4.890	4.890	5.230	5.230	5.230
Depth	(mm)	1.700	3.080	4.460	1.700	3.080	4.460	2.400	4.050	5.260	3.760	4.050	5.260
Height	(mm)	1.590	1.590	1.590	1.590	1.590	1.590	2.450	2.450	2.450	2.000	2.000	2.000
Weight	(kg)	3.700	5.800	7.900	3.750	5.800	7.900	4.400	9.200	14.000	4.500	9.500	14.500

ViRGO

Linen folding

3000-3300-3500 mm
width



Technical Specifications



PLC CONTROLLED
touch screen control panel

Automatic stacker and conveyor
for easy handling
double stacker&conveyor (optional)

Single lane 2 primary
3 cross folds

Double lane 2 primary 2
cross folds and stacking
(linen, f&b) (optional)

4 lanes, 2 primary folds
(f&b) (optional)

Blanket and duvet folding
(optional)



		Virgo 3000
Folding Capacity	(pcs/h)	1800
Working Speed	(m/min)	12-60 adjustable
Folding Dimensions	(cm)	40x40 - 300x300
Motor Power (total)	(Kw)	3
Primary / Cross Folding	(pcs)	2 primary / 3 cross
Width	(mm)	3.780 (5.145)
Depth	(mm)	3.220
Height	(mm)	1.750
Weight	(kg)	1.750 (2.050)



double lane folding



Technical Specifications



4 SPLIT INPUT CONVEYOR
with ability to fold up to
120 x 200 cm

PLC CONTROLLED
7" touch screen panel

**ABILITY TO FOLD AND SPLIT
ALL TOWEL GROUPS
AUTOMATICALLY**

**ACCURATE PRIMARY
FOLDING WITH AIR BLAST**

**HEIGHT ADJUSTABLE
INPUT CONVEYOR AND
DOUBLE OUTPUT FLAP**

Folding Capacity	(pcs/h)	800-1.250
Working Speed	(m/min)	64
Folding Dimensions	(cm)	40x40 - 120x200
Motor Power (total)	(Kw)	2
Primary / Cross Folding	(pcs)	2 primary / 2 cross
Width	(mm)	2.370
Depth	(mm)	3.554
Height	(mm)	1.360
Weight	(kg)	1.485



ViRGO

Towel Roller



Standart Features:

- Compact and easy usage
- 200-300 pcs/hour capacity
- Bottom Shelf (Optional)

Feeding Range	(mm)	650
Width	(mm)	935
Depth	(mm)	820
Height	(mm)	535
Weight	(kg)	140

ViRGO

Vacuum feeder

**3000-3300-3500 mm
width**



Vacuum Feeders are designed for huge capacity ironers in order to perform the most demanding high quality finishing tasks. It is suitable for linens, pillow cases, table napkins and table clothes. Ergonomic designed structure with high efficient centrifugal fans, a forceful airflow has created to catch, to flatten, to tauten and to feed the laundry. All movements such as string, bending, pulling fulfilled by operators normally, are done mechanically in order to achieve dramatically savings.

Besides by reducing the gap of fed linens in between, efficiency of the ironer has been raised up. According to type of fed material, speed and vacuuming are adjustable whereas feeder relocates easily with carrier wheels.

Feeder Weight	(mm)	3.000
Working Speed	(m/min)	6-36 adjustable
Motor Power (total)	(Kw)	0,55
Fan Motor Power	(Kw)	4 x 0,75
Width	(mm)	3.465
Depth	(mm)	1.155
Height	(mm)	1.350
Weight	(kg)	760

AUXILIARY EQUIPMENTS FOR LAUNDRIES

NEW

Dry Cleaning Machine



Auxiliary Equipments

- Tolkar Dry Cleaning Machines
- Presses
- Narrow Type Ironing Tables
- Air Form Finishers
- Stain Removers
- Shirt Robots And Collar & Cuff Presses
- Trolleys
- Mobile Working Tables
- Shelves
- Sink Units
- Garment Hanger Trolleys
- Marking Machines
- Packing Machines
- Conveyor Systems
- Steam Generators
- Air Compressors
- Sewing And Overlook Machines

Besides manufacturing the washer extractors, tumble dryers, flatwork ironers, TOLKAR intends to supply auxiliary equipments such as steam air formers, PVC or stainless steel laundry carts, pressing machines, narrow type ironing tables with generators, dry cleaning machines, garment rack trolleys or spot cleaning tables, steam generators, laundry shelves, marking machines, garment conveyor systems, air compressors, sewing machines etc. in order to provide complete turn key project for their customers. All auxiliary equipments are subject to be supplied according to needs of our customers as dimensions, raw materials and/or specifications by TOLKAR.

Press Ironer		
Voltage	(V)	380
Steam Pressure	(bar)	4
Motor Power	(Kw)	0,55
Width	(mm)	1.500
Depth	(mm)	1.200
Height	(mm)	1.330
Weight	(kg)	390

Paskala Ironer		TPU	TPUK
Voltage	(V)	220	220
Resistance Power	(W)	1.500	6.700
Steam Pressure	(bar)	3	3
Motor Power	(Kw)	0,37	0,37
Width	(mm)	1.380	1.380-350
Depth	(mm)	430	430-400
Height	(mm)	920	920-110
Weight	(kg)	70	71-17

DISTRIBUTORSHIPS



CHICAGO[®]

RENZACCI

Speed Queen[®]

LAVATEC

in Turkey with Tolkar assurance



COLMAC



EBIKO

TOLKAR Memorial Forest Constituted with Our Esteemed Customers



Some of Our Business Partners Contributed to Our Social Responsibility Project







Our Spare Parts Web Site

www.tolkarspareparts.com.tr

Sales & Aftersales Branch Offices

ADANA BRANCH:

Reşatbey Mahallesi Avukat Mahmut Eroğlu Sokak
Tatlıldil Apt. No:3/A Seyhan - ADANA
Phone: +90 322 457 48 79 Fax: +90 322 457 48 80

ANKARA BRANCH:

Türk Ocağı Caddesi No: 32 Balgat - ANKARA
Phone: +90 312 286 06 09 (pbx) Fax: +90 312 286 00 61
Gsm: +90 533 738 88 59

ANTALYA BRANCH:

Meydan Mah. Aspendos Bulvarı No:34
Muratpaşa - ANTALYA
Phone: +90 242 228 25 54 (pbx) Fax: +90 242 228 45 36

ALANYA BRANCH:

Sugözü Mah. Zamanoğlu Caddesi Çevreyolu üzeri
Mansion 2 Apt. No:55 ALANYA
Phone: +90 242 512 69 42 Fax: +90 242 512 93 26

BODRUM BRANCH:

Yokuşbaşı Mahallesi Milas Caddesi No: 9/1
Bodrum - MUĞLA
Phone & Fax: +90 252 313 74 92 - 313 46 68
Gsm: +90 533 765 48 13

DİYARBAKIR BRANCH:

Şanlıurfa Yolu Üzeri Orköy Kavşağı 466. Sokak
Öncüoğlu Sitesi Altı B /Blok
Kayapınar - DİYARBAKIR
Phone: +90 412 251 18 72 Fax: +90 412 251 18 73

İSTANBUL BRANCH:

Bahriye Caddesi No:89 Kasımpaşa - İSTANBUL
Phone: +90 212 255 37 47 Fax: +90 212 255 37 49
Gsm: +90 533 738 88 54

NOTRHERN CYPRUS BRANCH:

Merkez: Alayköy Sanayi Bölgesi 7. Cadde
No:38 Alayköy - LEFKOŞA
Phone: +90 392 22 34 325
Gsm: +90 533 859 66 66

Aftersales Branch Offices

AFYON SERVICE OFFICE:

Güvenler Mahallesi
Kocatepe Caddesi No:33/2 AFYONKARAHİSAR
Gsm: +90 533 622 05 24

BURSA SERVICE OFFICE:

Çekirge Uludağ Yolu Caddesi Feşçioğlu Sitesi
B-Blok No: 35 BURSA
Phone: +90 224 239 35 59 Fax: +90 224 239 35 60
Gsm: +90 533 720 41 84

ERZURUM SERVICE OFFICE:

Palandöken Kazım Yurtalan Mah. Şehit Erdal Pişken Cad.
No:76 Palandöken - ERZURUM
Phone & Fax: +90 442 317 12 66
Gsm: +90 533 275 40 20

KAYSERİ SERVICE OFFICE:

Uğurevler Mahallesi Koca Sinan Bulvarı
No:274 Koca Sinan - KAYSERİ
Gsm: +90 533 720 41 82

MANAVGAT SERVICE OFFICE:

İllica Mah. Cumhuriyet Bulvarı No:16/1
İllica - Manavgat - ANTALYA
Phone: +90 242 228 25 54 (pbx) Fax: +90 242 228 45 36

MARMARİS SERVICE OFFICE:

Mustafa Kemal Paşa Caddesi No: 9
Datça Yolu Üzeri Aspak Sistem
Armutalan - MARMARİS
Phone: +90 252 417 11 83 Fax: +90 252 417 59 84
Gsm: +90 533 371 80 71

SAMSUN SERVICE OFFICE:

Kılıçdede Mahallesi Çubukçu Sokak No: 4/A SAMSUN
Phone: +90 362 230 35 46 Fax: +90 362 230 35 47
Gsm: +90 533 482 64 41

TRABZON SERVICE OFFICE:

1 Nolu Beşirli Harita Caddesi Çınarüstü Siteleri
C Blok Kat:1 Daire:3 TRABZON
Gsm: +90 533 683 12 98

www.tolkar.com.tr

info@tolkar.com.tr

TOLKAR®

Technological, Ecological, Economical Differences

SMARTEX®

A.Ö.S.B. 10036 Sokak No:6 35620 Çiğli - İzmir
Phone: +90 232 376 8500 (pbx) • Fax: +90 232 376 7658
info@tolkar.com.tr

www.tolkar.com.tr

